

***M-175  
Personal  
Communication  
Transmitter***

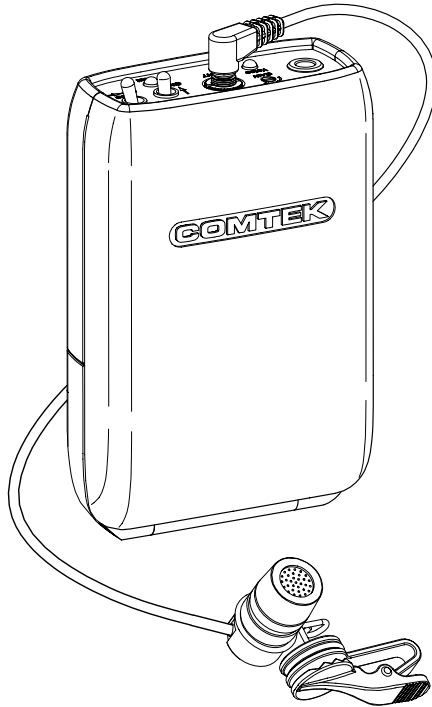

---

---

**COMTEK®**

# TABLE OF CONTENTS

---

---

Introduction .....	1
Setup .....	2
Controls .....	3
Battery Removal / Replacement .....	4
Battery Charging .....	5
Auxiliary Audio Input Operation .....	6-7
Snap-On Belt Clip .....	7
Frequency Selection .....	8
Frequency Information .....	9-10
Optional Accessories .....	11
Specifications .....	12
Warranty and Service .....	13

## INTRODUCTION

---

# **M-175** **Personal** **Communication** **Transmitter**

The M-175 personal transmitter is a professional quality, compact body-worn transmitter designed for reliable one-way remote communication. It's ideal for many applications including: personal cueing, assistive listening, tour guide presentations, communication for on-the-job training, (requiring being some distance away or in a noisy environment), and other personal, one-way remote communication situations.



For a natural sound, this transmitter incorporates the latest digital and analog technologies to produce high quality sound with low residual noise, wide dynamic range and extended frequency response.

The audio processing circuit allows a choice of companded 2:1 audio processing when used with Comtek full fidelity receivers, or non-companded 1:1 audio processing on prescribed channels with Comtek and other lower cost popular receivers. Both audio processing systems have the same frequency response of 80 Hz to 10 KHz. Operating under F.C.C. Regulation Part 90, the M-175 transmitter has greater transmission range and reliability.

## M-175 SETUP

---

---

### Setup

a. Check to ensure that the M-175 transmitter's radio frequency channel is the same as the associated COMTEK receiver's channel. (Channels are indicated by the rotary channel selector switches on the back of the transmitter. See page 8.)

b. Open the battery door cover on the transmitter (see page 4) and insert a new nine volt alkaline battery (Eveready E522 or equivalent). This type of battery will offer up to 14 hours of operation. *Replace the battery before every use if the demand for fail-safe operation outweighs battery cost. The use of carbon batteries is not recommended.*

**NOTE: If a rechargeable battery is to be used, ensure that it has been allowed to charge at least twelve hours to bring it to full charge (see page 5 for battery charger instructions).**

c. Connect the microphone to the transmitter by inserting the microphone plug into the receptacle on the top of the transmitter. The transmitter is operating when the transmitter power switch is turned on and the battery status/on indicator illuminates.

**NOTE: The 48-inch microphone cord also functions as part of the transmitter's antenna system. For optimum performance, this cord should be fully extended. Coiling or bunching the microphone cord may reduce the range of the transmitter. The transmitter should be carried by the snap-on belt clip (included) or in a pocket or belt-clip pouch.**

d. In a situation where an extremely loud voice or a very soft voice is used, it is necessary to adjust the audio input gain control while observing the audio "voice" level modulation indicator. A full bright LED indicates full audio compression at 100% modulation. For best performance, the audio input gain should be adjusted for some low level LED luminescence during normal audio levels with occasional full bright peaks indicating 100% modulation.

# M-175 CONTROLS

---

**❶ COMPAND AUTO / OFF SWITCH:** This switch overrides the automatic selection of the companded channels for non-companded operation. (This switch should remain in the “Auto” position.)

**❷ CHANNEL SWITCHES:** These rotary switches are used to set the transmitter to the desired operating frequency. (See page 9 and 10 for frequency selection chart.)

**❸ BATTERY COMPARTMENT:** The battery compartment features a hinged battery cover and an alignment system that ensures proper battery polarity. Battery installation and removal is facilitated by simply manipulating the bottom of the battery.

**❹ AUXILIARY AUDIO INPUT JACK:** Allows transmitter to use line level, earphone level, or fixed AUX as an audio source.

**❺ AUDIO “VOICE” MODULATION INDICATOR:** This indicator is used in making adjustment with the Audio Input Gain Control.

**❻ MIC / ANTENNA JACK:** This jack accepts an electret type microphone having a 48” long cord with a micro-mini 2.5 mm mono plug. The microphone cord functions as part of the transmitter’s antenna system and must be in place for auxiliary audio input operation. If microphone function is not necessary, the optional microphone switch should not be on for this operation.

**❼ POWER / BATTERY STATUS INDICATOR:** This LED indicator will illuminate continuously when the unit is on indicating normal operation. When the battery voltage drops below 6 volts, the LED will flash *rapidly*, indicating that a new battery is needed.

**❽ OPTIONAL MIC SWITCH:** This switch turns off the microphone without turning off the transmitter carrier.

**❾ AUDIO INPUT GAIN CONTROL:** This is a microphone and AUX level input gain control. This control is used with the “Voice” modulation indicator.

**❿ ON / OFF SWITCH:** This switch turns the transmitter on and off.

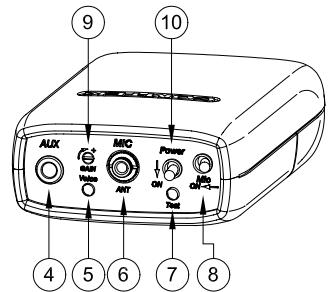
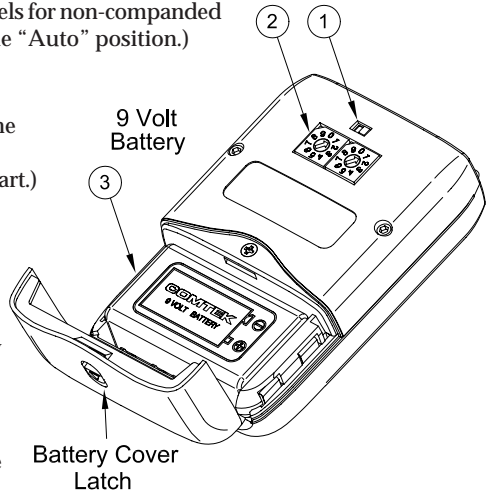

## M-175 BATTERY REMOVAL / REPLACEMENT

---

---

### Low Battery Indicator

The LED on the top of the transmitter indicates the status of the battery as well as indicating that the unit is turned on. When the transmitter is turned on, the LED illuminates. If the battery is low, the green LED will blink rapidly to warn you that the battery will soon be dead. Replace a low battery immediately.

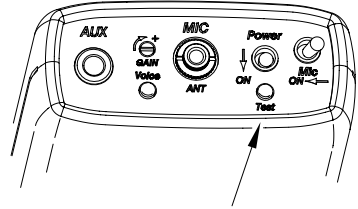

Battery indicator LED

### Battery Removal / Replacement

*Pull back battery door latch and allow battery cover door to spring open. To remove battery, simply manipulate the bottom of battery out of the compartment and remove.*

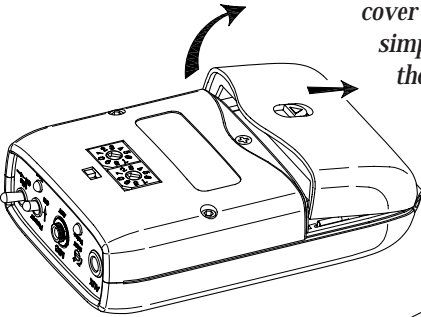

*To insert battery, face battery with negative terminal in line with large hole in battery compartment, press battery into compartment and close battery door until it snaps shut. Note: It is not possible to put battery in backwards.*

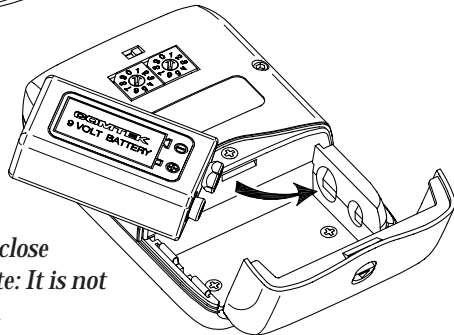

# M-175 BATTERY CHARGING

---

---

## Battery Charging

1. Make sure that a seven cell 9 volt Ni-MH rechargeable battery is used with a minimum of 200 mAh capacity. **(Alkaline batteries must not be charged.)**
2. Make sure the M-175 is turned **OFF**.
3. Note that the red charging indicator on the charger is **ON** when the M-175 is plugged into the charger through the audio output jack.
4. When using the **NBC 9-2C** charger allow the battery to charge for 14 hours for a full charge. Unit must then be unplugged. When using the **NBC 9-3-1** digital fast charger the charger will automatically end the charge cycle and the red LED will change to green. With the **NBC 9-3-1** charger the unit may be left in the charger until the unit is used.
5. Periodically open the battery compartment on stored COMTEK units to check for battery leakage. If a battery is leaking, it must be discarded, and the battery compartment must be cleaned or returned to COMTEK's service department for repairs.

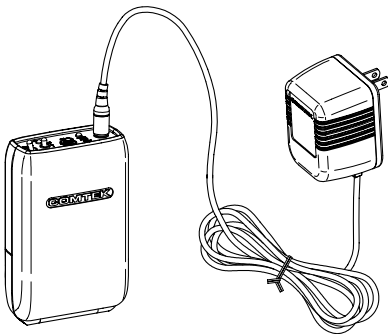

**NBC 9-2C**  
**14-hour charger**

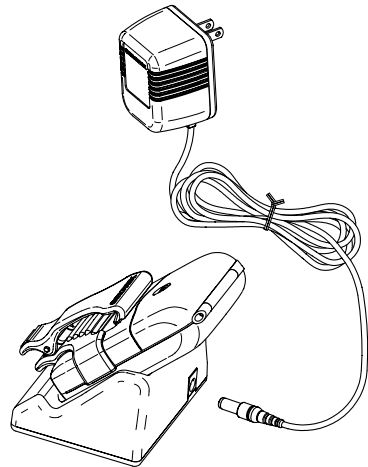

**NBC 9-3-1**  
**digital fast charger**

# M-175 AUXILIARY AUDIO INPUT OPERATION

---

---

## Auxiliary Audio Input Operation

The M-175 transmitter may transmit from a variety of audio sources such as digital media players, or any audio device having an auxiliary or earphone level audio signal.

The auxiliary input cable supplied with the M-175 transmitter (CB-36 ST) will operate with any device having a mini 3.5 mm jack, stereo or mono, and with line level or earphone level output.

To accommodate a variety of specialty applications, auxiliary input cables with RCA phono plug, 1/4" audio phone plug, and XLR connectors are available from COMTEK.

### Setup

a. Connect the microphone to the transmitter by inserting the microphone plug into the receptacle on the top of the transmitter.

**Note: The microphone cord functions as part of the transmitter's antenna system and must be in place for auxiliary audio input operation. If microphone function is not necessary, the optional microphone switch should not be on for this operation.**

b. Connect the proper auxiliary input cable to the audio source. Connect the right-angle mini plug end of the auxiliary input cable into the "AUX" input jack of the M-175 transmitter.

**Note: Check to ensure that the audio source is a line level, earphone level, or fixed AUX level output.**

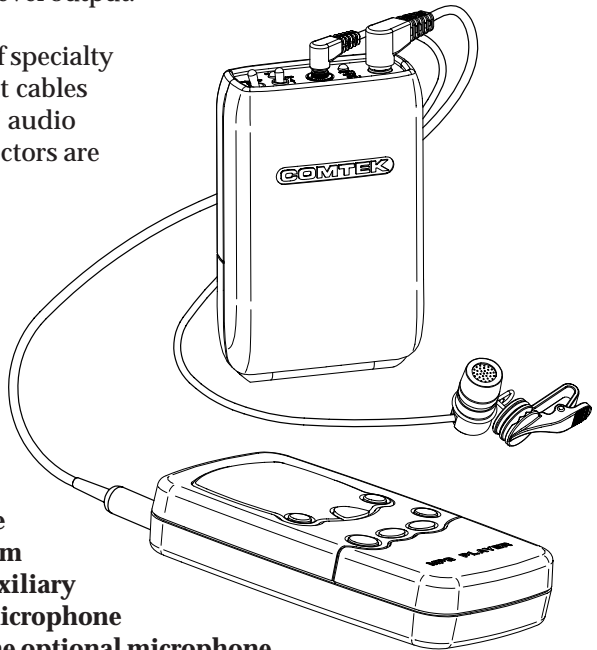

## M-175 AUX OPERATION (Cont.) / SNAP-ON BELT CLIP

c. Turn on the transmitter with program from the audio source being fed to the transmitter. Observe the audio “voice” level modulation indicator. A full bright LED indicates full audio compression at 100% modulation. For best performance, the audio input gain should be adjusted for some low level LED luminescence during normal audio levels with occasional full bright peaks indicating 100% modulation.

d. When using the auxiliary audio input with the microphone plugged into the transmitter, priority should be given to the microphone gain adjustment. The mixing balance between the auxiliary audio and the microphone should be made with the volume control of the auxiliary audio source.

**Note: The optional microphone switch only affects the microphone. It does not affect the auxiliary audio input.**

### M-175 SNAP-ON BELT CLIP (Included)

#### Belt clip installation

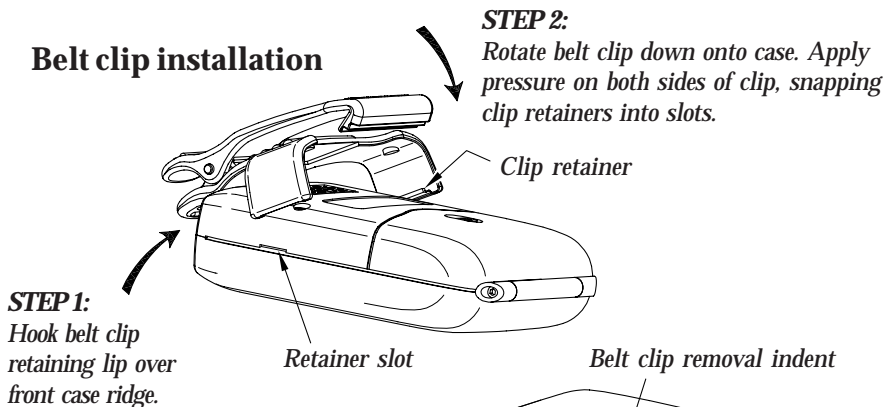

#### Belt clip removal

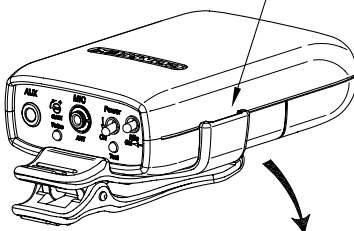

*Flex out and pull down with your thumb or a large coin (quarter) to unsnap belt clip from case.*

# M-175 FREQUENCY SELECTION

---

---

## Frequency Selection (72-76 MHz)

The M-175 transmitter can operate on one of 88 available channels between 72-76 MHz. COMTEK channel designations indicate both standard non-companded channels and high-fidelity companded channels. Channels 1-88 are to be used only with receivers having 2:1 audio companding processing. Channel position 91-00 is to be used only with receivers having linear non-companded audio processing. COMTEK transmitters automatically transmit the proper modulation when set to either number channels 1-88 or channels 91-00 (A-J).

**Note: The compand switch should remain in the “Auto” position.**

After you have determined the channel on which you are going to operate, position the two rotary switches to indicate the channel. The left rotary switch is for *tens* and the right rotary switch is for *ones*, e.g. to select channel 41 (72.92 MHz), position the left rotary switch to point to 4 (X10), and position the right rotary switch to point to 1 (X1).

*Refer to frequency charts on pages 9 and 10 for selectable frequencies.*

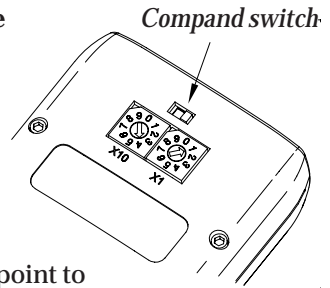

## Multiple Channel Operation

When multiple transmitters are broadcasting in the same immediate area (within 100 feet), the RF signals will “mix” together generating additional signals. If these product frequencies are too close to a frequency which you are using, you will experience intermodulation interference. This condition is common to all radio receivers to some extent.

Simultaneous operation of more than three channels requires frequency coordination to avoid intermodulation interference which could result in poor or unusable performance.

***To avoid this type of interference, you should select frequencies from one of the standard groups (see group frequency charts on pages 9 and 10), or use COMTEK’s frequency selection software available at [www.comtek.com](http://www.comtek.com) to determine appropriate frequencies or contact COMTEK to obtain a free copy.***

# M-175 FREQUENCY INFORMATION

## 72-76 MHz STANDARD COMPANDED CHANNELS

CHAN	FREQ	CHAN	FREQ	CHAN	FREQ
01	72.02 MHz	35	72.80 MHz	69	75.58 MHz
02	72.04 MHz	36	72.82 MHz	70	75.62 MHz
03	72.06 MHz	37	72.84 MHz	71	75.64 MHz
04	72.08 MHz	38	72.86 MHz	72	75.66 MHz
05	72.10 MHz	39	72.88 MHz	73	75.68 MHz
06	72.12 MHz	40	72.90 MHz	74	75.70 MHz
07	72.14 MHz	41	72.92 MHz	75	75.72 MHz
08	72.16 MHz	42	72.94 MHz	76	75.74 MHz
09	72.18 MHz	43	72.96 MHz	77	75.76 MHz
10	72.20 MHz	44	72.98 MHz	78	75.78 MHz
11	72.22 MHz	45	74.61 MHz	79	75.80 MHz
12	72.24 MHz	46	74.63 MHz	80	75.82 MHz
13	72.26 MHz	47	74.65 MHz	81	75.84 MHz
14	72.28 MHz	48	74.67 MHz	82	75.86 MHz
15	72.30 MHz	49	74.69 MHz	83	75.88 MHz
16	72.32 MHz	50	74.71 MHz	84	75.90 MHz
17	72.34 MHz	51	74.73 MHz	85	75.92 MHz
18	72.36 MHz	52	74.75 MHz	86	75.94 MHz
19	72.38 MHz	53	74.77 MHz	87	75.96 MHz
20	72.40 MHz	54	74.79 MHz	88	75.98 MHz
21	72.42 MHz	55	75.21 MHz		
22	72.46 MHz	56	75.23 MHz		
23	72.50 MHz	57	75.25 MHz		
24	72.54 MHz	58	75.27 MHz		
25	72.58 MHz	59	75.29 MHz		
26	72.62 MHz	60	75.31 MHz		
27	72.64 MHz	61	75.33 MHz		
28	72.66 MHz	62	75.35 MHz		
29	72.68 MHz	63	75.37 MHz		
30	72.70 MHz	64	75.39 MHz		
31	72.72 MHz	65	75.42 MHz		
32	72.74 MHz	66	75.46 MHz		
33	72.76 MHz	67	75.50 MHz		
34	72.78 MHz	68	75.54 MHz		

Automatic Non-Companded Channels	
CHAN	FREQ
91	72.1 MHz
92	72.3 MHz
93	72.5 MHz
94	72.7 MHz
95	72.9 MHz
96	75.5 MHz
97	75.7 MHz
98	75.9 MHz
99	74.7 MHz
00	75.3 MHz

### GROUP 1

CHAN	FREQ
01	72.02 MHz
11	72.22 MHz
31	72.72 MHz
45	74.61 MHz
70	75.62 MHz
75	75.72 MHz

### GROUP 2

CHAN	FREQ
04	72.08 MHz
09	72.18 MHz
31	72.72 MHz
53	74.77 MHz
69	75.58 MHz
85	75.92 MHz

### GROUP 3

CHAN	FREQ
13	72.26 MHz
25	72.58 MHz
54	74.79 MHz
57	75.25 MHz
81	75.84 MHz
87	75.96 MHz

## Transmitter Proximities For Multiple Channel Operation

Frequency groups being transmitted should be separated by 2X the operating area; and for best performance, the group operating areas should have a 100 ft. minimum separation.

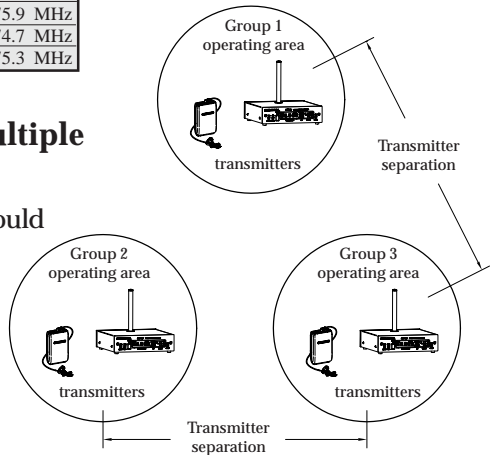

## M-175 FREQUENCY INFORMATION (Continued)

### M-175 LETTER CHANNELS (72-76 MHz)

#### GROUP 1

Standard Non-Companded Channels (For PR-72b and PR-75)	
CHANNEL	FREQUENCY
91	A 72.1 MHz
92	B 72.3 MHz
93	C 72.5 MHz
94	D 72.7 MHz
95	E 72.9 MHz
96	F 75.5 MHz
97	G 75.7 MHz
98	H 75.9 MHz
99	I 74.7 MHz
00	J 75.3 MHz

CHANNEL	FREQUENCY
91	A 72.1 MHz
95	E 72.9 MHz
98	H 75.9 MHz
00	J 75.3 MHz

#### GROUP 2

CHANNEL	FREQUENCY
92	B 72.3 MHz
97	G 75.7 MHz
99	I 74.7 MHz

#### GROUP 3

CHANNEL	FREQUENCY
93	C 72.5 MHz
96	F 75.5 MHz

**Note: Although the same frequencies appear in the companded and non-companded frequency charts, non-companded channels should not be used with companded receivers.**

In order to accommodate a greater variety of receivers, the M-175 transmitter incorporates the option to operate with receivers that have companded or non-companded audio processing. However, the M-175 transmitter must operate non-companded with non-companded receivers and companded only with receivers that incorporate companding processing. A mismatch will result in unacceptable audio performance.

#### ***Basic Companding Theory***

The dynamic range of the audio signal is compressed in the transmitter at a 2:1 ratio. The receiver then expands the audio signal at a complementary 1:2 ratio to restore the dynamic range of the audio signal to the original level and also to provide additional noise reduction when no audio signal is present.

# M-175 OPTIONAL ACCESSORIES

---

---

## Optional Accessories

1. NBC 9-2C Battery charger
2. NBC 9-3-1 Digital fast charger
3. NBC 9-3-12 Digital 12-station fast charger
4. NH9-200 Rechargeable batteries
5. BC-216 Snap-on belt clip (supplied with M-175)
6. P1 Universal pouch
7. SM-185 Unidirectional electret condenser microphone
8. PSC-HM Headworn unidirectional electret microphone

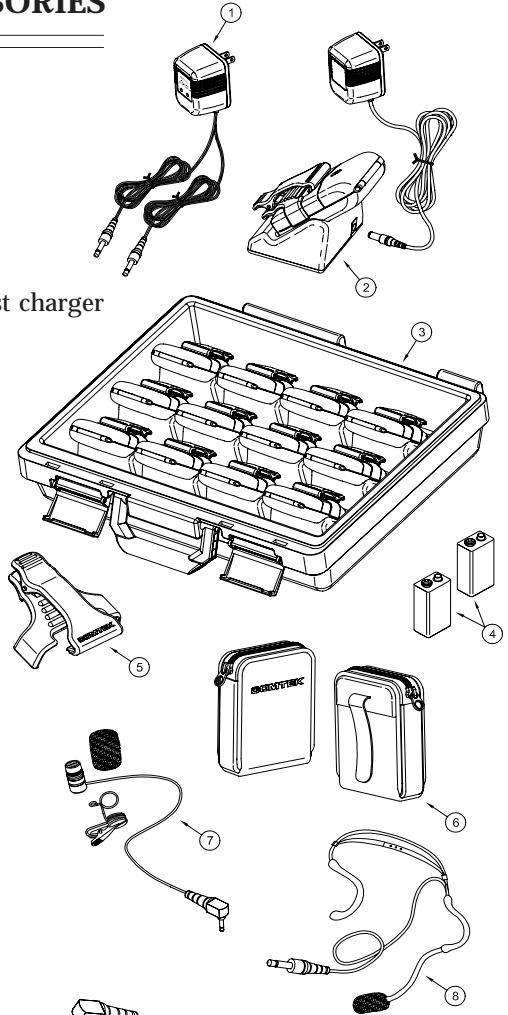

## Auxiliary Audio Input Cords

9. CB-36 STM Stereo mini 3.5 mm (supplied with M-175)
10. CB-36 RCA Phono plug (optional)
11. CB-36 ST1/4 Stereo 1/4" (optional)
12. CB-36 XLR XLR-F 3 pin connector (optional)

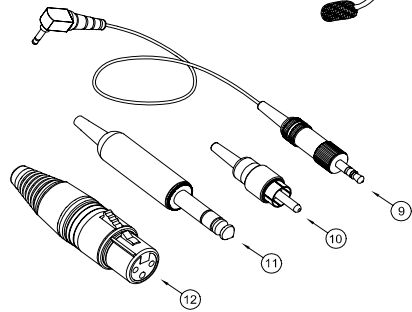

# M-175 SPECIFICATIONS

---

---

## Audio Input:

- Microphone input impedance for electret type microphone - 3000 ohm
- Aux/Line input impedance - 10 k ohm at 0 dBV nominal

## Connectors:

Microphone - Micro-mini mono 2.5 mm

Auxiliary - Mini stereo 3.5 mm

Audio: Tip and sleeve

Battery Charging: Tip and sleeve

## Controls and Indicators:

- Synthesized channel selection switches
- Power On/Off switch
- Optional microphone switch
- Audio input gain control
- Power/Battery status indicator
- Audio (voice level) modulation indicator
- Manual/Automatic compand switch

## Frequency Response:

80 Hz to 10 kHz

## Audio Distortion:

Less than 1% at 80% modulation

## Modulation Limiter:

Soft compressor with 30 dB linear overload protection; attack time - less than 1 ms, recovery time - 10 ms

## Frequency Modulation:

10 kHz deviation companded

## Operating Radio Frequency:

88 synthesized channels in the 72-76 MHz band.

## Out-of-Band Emissions:

Better than 50 dB below carrier

## R.F. Stability:

20 ppm XTL controlled  
Digitally synthesized

## RF Power Output:

40 mW to antenna system

## FCC Compliance:

Type Accepted under FCC Part 90

## Antenna System:

Body-worn microphone cord.

## Current Drain:

35 mA average current

## Battery:

- 9 volt alkaline Eveready 522 or equivalent for up to 14 hours of use
- Rechargeable 9 volt Ni-MH 200 mAh battery for up to 7 hours of operation
- Rechargeable 9 volt Lithium Polymer 500 mAh battery for up to 14 hours of use

## Dimensions:

1 1/16" x 2 1/4" x 3 1/2"  
(27 mm x 57 mm x 89 mm)

## Weight:

5 ounces (140 grams)

NOTE: Specifications subject to change without notice or obligation

# M-175 WARRANTY AND SERVICE

---

---

## Warranty

COMTEK warrants this product to be free from defects in workmanship and material under normal use and conditions for a period of one year from date of original purchase. Items such as batteries, neckloops, and cords are not covered by the warranty. Damage due to misuse, ill treatment and unauthorized modification and repairs are not covered by this warranty. COMTEK is not liable for consequential damages arising out of any failure of the equipment to perform as intended. COMTEK shall bear no responsibility or obligation with respect to the manner of use of any equipment sold by it. COMTEK SPECIFICALLY DISCLAIMS AND NEGATES ANY WARRANTY OF MERCHANTABILITY OR FITNESS FOR A PARTICULAR PURPOSE OF SUCH EQUIPMENT INCLUDING, WITHOUT LIMITATION, ANY WARRANTY THAT THE USE OF SUCH EQUIPMENT FOR ANY PURPOSE WILL COMPLY WITH APPLICABLE LAWS AND REGULATIONS.

## Service Policies

Warranty repairs must be done by COMTEK. Only factory technicians are authorized to perform warranty service on the M-175 transmitter. Before returning the M-175 for service, a Return Authorization Number should be obtained from the service department by calling 1-800-496-3463 or 1-801-466-3463. Return the unit to the factory with the original or comparable packing. COMTEK will pay for insurance and ground return shipping costs in the United States for all warranty service.

---

---

# COMTEK®